



We Power Your World!

GPW2600 GAS PRESSURE WASHER MANUAL



Green-Power America, LLC

GPW2600 GAS PRESSURE WASHER

Products Service Information

Green-Power America LLC thanks you for choosing a **Green-Power America LLC** product.

Please register your product within 10 days of purchase to ensure that you receive optimal service. Always keep copy of your original receipt.

By registering your product, you are protected:

1. You have a record of the product purchase,
2. Customer Service can Better serve you on Warranty related issues
3. Green-Power America will be able to contact you in the unlikely event that a product recall notification is necessary.

You can register your product in one of two ways follows:

Option 1: go to the Green Power America website at www.green-poweramerica.com/service (or www.g-poweramerica.com/service) and follow the instruction to register online.

Option 2: Fill out the form on the Warranty Card included in the box, and return via standard mail to **Green Power America, LLC** at 840 9th Street suite H, Upland CA 91786. Please note that postage is required to mail the registration form back to **Green-Power America, LLC**.

If you still have any questions regarding the usage or operation of the product after you have read the manual, or if you have any quality issue during operation, please call our toll-free service number shown below:

For any issues related to **LCT** Engine, the parts include recoil starter, air filter, spark plug, and all the other parts fixed to the engine, please go to (**LCT** website) www.lctusa.com or call **Toll-Free** number:

800-558-5402

For any issues related with the remaining parts except for the **LCT** Engine parts, including pump, Spay Gun, Pressure hose, wand, and other parts, please call **Toll-Free** number:

888-834-4218

You may reach us by visiting our web www.green-poweramerica.com (or www.g-poweramerica.com) or sending us emails to:

service@green-poweramerica.com

GPW2600 GAS PRESSURE WASHER

CONTENTS

SPECIFICATIONS	4
SAFTY INSTRUCTION	5-8
INTRODUCTION	9
PART LIST	10-11
ASSEMBLY INSTRUCTIONS	12
PREPARATION.....	13-14
OPERATING INSTRUCTION	15-20
TROUBLESHOOTING	21-22
MAINTENANCE	23-24
STORAGE	25-26

GPW2600 GAS PRESSURE WASHER

1, SPECIFICATIONS





Model Number	GPW2600
Maximum Pressure	2600 psi
Rated Pressure	2000 psi
Rated volume	2.0gpm
Minimum Inlet Pressure	30 psi
Maximum Inlet Pressure	100 psi
Pump	Heavy-duty maintenance-free axial cam
Thermal Relief Valve	Included
Minimum Temperature of Pumped Water	41°F(5°C)
Maximum Temperature of Pumped Water	140°F(60°C)
Inlet & Discharge Ports	3/4" (19 mm) standard garden hose connector
High Pressure Hose Length	25' (7.6 m)
Engine Displacement	208 cc
Engine Power	7.0 HP
Engine Running Speed (without load)	3600rpm
Fuel type	Unleaded Gasoline
Fuel tank capacity	2.7 L
Oil type	SAE 10W-30
Oil capacity	0.6 L
Wheel	9"
Detergent tank	0.79 G (3.0 L)

2, SAFETY INSTRUCTIONS

WARNING

To reduce the risk of serious injury, read all instructions and precautions before operating this machine.

SYMBOL MEANINGS:

	TOXIC	This symbol warns you of possible toxic gases which can be harmful to your health or deadly if you are exposed to them.
	FLAMMABLE AND COMBUSTIBLE MATERIALS	This symbol warns of materials/gases which are present and extremely flammable. When you see this symbol, be very cautious not to ignite the material/gases.
	VERY POISONOUS	This symbol warns of materials, gases, etc. which are very poisonous and would cause serious bodily harm or death. When you see this symbol, please take proper precautions.
	HOT SURFACE	This symbol warns of a hot surface which could cause damage to material and/or damage to human skin if touched. Please take proper precautions when you see this symbol.
	GENERAL WARNING	This symbol indicates that serious bodily injury or death could occur if proper precautions are not taken. These are warning statements which do not fall into the above categories



EXHAUST FUMES ARE DANGEROUS

- Never operate unit in enclosed areas such as garages, basements, storage, sheds, or in any location occupied by humans or animals. Never operate the engine in a closed area or it may cause unconsciousness and death within a short time. Operate pressure washer in clean, dry, well-ventilated area.
- Keep children, pets and others away from area of operating unit. Breathing exhaust fumes will cause serious injury or death.

 **WARNING - Gasoline engines produce toxic carbon monoxide exhaust fumes.**

GPW2600 GAS PRESSURE WASHER



INADEQUATE VENTILATION

- Materials placed against or near the pressure washer or operating in areas where the temperature exceeds 40°C ambient (such as storage rooms or garages) can interfere with its proper ventilation features causing overheating and possible ignition of the materials or buildings.
- Operate pressure washer in a clean, dry, well-ventilated area a minimum of 4' (1.2 m) from any building, object or wall. **DO NOT OPERATE UNIT INDOORS OR IN ANY CONFINED AREA.**



FUEL IS HIGHLY FLAMMABLE AND POISONOUS

- Always turn off the engine when refuelling.
- Never refuel while smoking or in the vicinity of an open flame.
- When operating or manoeuvring this pressure washer, be sure to keep it upright. If it tilts, fuel may leak from the carburettor or fuel tank.



DO NOT ATTEMPT TO FILL GASOLINE TANK WHILE ENGINE IS RUNNING

- Gasoline and gasoline vapours can become ignited by coming into contact with hot components such as the muffler, engine exhaust gases, or from an electrical spark.
- Turn engine off and allow it to cool before adding fuel to the tank. Equip the area of operation with a fire extinguisher certified to handle gasoline or fuel fires.



SPARKS, FIRE, HOT OBJECTS

- Cigarettes, sparks, fires, or other hot objects can cause gasoline or gasoline vapours to ignite.

GPW2600 GAS PRESSURE WASHER



ENGINE AND MUFFLER MAY BE HOT

- Place the pressure washer in an appropriate location, away from children and pedestrians.
- Avoid placing any flammable materials near the exhaust outlet during operation or shortly thereafter.
- Keep a 4' (1.2 m) clearance from buildings or other equipment around the pressure washer to prevent overheating.
- **WARNING - The engine muffler will be very hot during and after use, avoid touching the engine or muffler while they are still hot.**



HOT MUFFLER & HIGH PRESSURE HOSE

- Muffler will become very hot during operation. DO NOT TOUCH MUFFLER WHILE IN USE OR SHORTLY THERE AFTER.
- Keep hose away from the hot muffler or it may damage the hose. Do not use a damaged high pressure hose. Do not kink the high pressure hose.

NEVER OPERATE UNDER THE FOLLOWING CONDITIONS

- When a noticeable change in engine speed occurs.
- Engine misfires.
- Loss of water pressure.
- Smoke or flames in the area.
- Excessive vibration.



WATER SPRAY

- Never direct the water spray towards ANY person, animal, electrical wiring or the pressure washer itself.
- DO NOT spray too close to the surface or damage could occur.
- The vendor is not responsible for damage caused by improper use.

GPW2600 GAS PRESSURE WASHER



PREVENT ACCIDENTAL WATER SPRAY

- To prevent accidental water spray, the wand trigger should be placed in the locked position when not in use.



KEEP HANDS AWAY

- Keep hands and other body parts away from high pressure water stream as water pressure will cause severe bodily harm.



SAFETY GLASSES

- Always wear safety glasses while operating.

DETERGENTS

- Only use recommended detergents for pressure washers. Using detergents not specifically recommended for use with pressure washers can cause damage to pump and other pressure washer components.
- DAMAGE CAUSED TO PRESSURE WASHER UNIT BY USING NON-RECOMMENDED DETERGENT IS NOT COVERED UNDER WARRANTY.

COLD WEATHER STARTS

- Do not operate this pressure washer in temperatures below 5°C. Operating pressure washer under the temperature of 5°C may cause damage to pump and other pressure washer parts.
- DAMAGE TO PRESSURE WASHER UNIT BY USER MISUSE IS NOT COVERED UNDER WARRANTY.

SAFETY FEATURES

- **Thermal Relief Valve**
Protects the pump from overheating in case nozzle becomes clogged. This system should not be abused. Make every effort to prevent the pump from overheating.
- **Low-Oil Auto Shut-Off**
This pressure washer is equipped with a low oil shut-off system. If the engine oil level goes below the recommended oil level, the pressure washer will automatically shut-off. This protects your engine and prevents operating without proper lubrication.

GPW2600 GAS PRESSURE WASHER

PREVENT PUMP DAMAGE

- Do not run the pressure washer engine for more than 5 minutes without pressing the wand trigger or damage to the pump may result.
- Never let the machine run unless connected to the water supply. Ensure water supply is running water through the pressure washer before attempting to start engine.
- Never run caustic fluids or acid through this machine.

GPW2600 GAS PRESSURE WASHER

3, INTRODUCTION

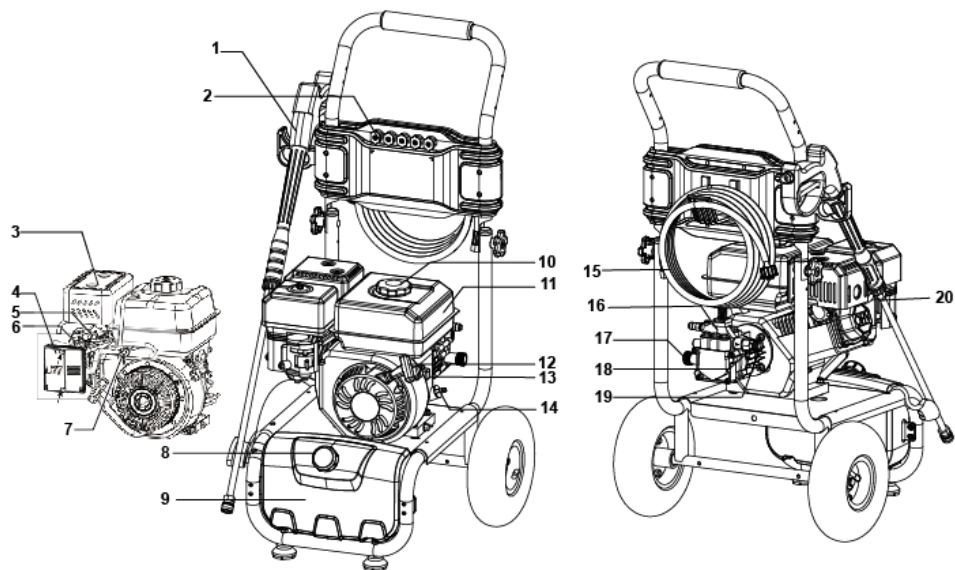





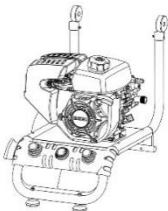

Ref.	Description
1	Spray gun
2	Nozzles
3	Muffler
4	Air filter
5	Throttle lever
6	Choke lever
7	Fuel valve
8	Detergent tank cap
9	Detergent tank
10	Fuel tank cap

Ref.	Description
11	Fuel tank
12	Hand cord
13	Engine switch
14	Oil dipstick
15	Pressure hose
16	Detergent suction connector
17	Inlet of pump
18	Thermal relieve valve
19	Outlet of pump
20	Spark plug

GPW2600 GAS PRESSURE WASHER

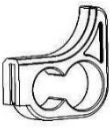
4, PART LIST

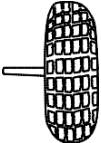
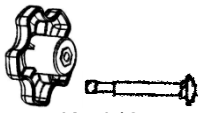
 Frame *1	 Handle *1
 Pressure hose *1	 Gun *1 Wand *1
 Gun holster *1	 Hose hook *1
 Wheel *2	
 Knob*2	

Others: Manual *1; Nozzle cleaner*1; Spark plug wrench *1; O-ring*2 (1for pressure hose, 1for spray gun).

⚠WARNING! Before attempting to start pressure washer, ensure you complete the following important steps.

- 1) Fill gasoline tank with Unleaded Gasoline. This is a 4-cycle engine with separate reservoirs for gas and oil. **DO NOT** use pre-mixed gas! **DO NOT** use old gas! Fuel must be purchased separately.
- 2) Fill oil tank with SAE 10W-30 oil. Running pressure washer without oil will severely damage engine which is not covered by warranty! Oil must be purchased separately.

GPW2600 GAS PRESSURE WASHER

- 3) Ensure both the pressure hose and garden hose have been correctly attached to the pressure washer pump. Ensure the water tap is on and water is running through the hose before attempting to start engine. Not doing this will damage the pump!

5, ASSEMBLY INSTRUCTIONS

1. Lift the frame with one hand and attach one of the wheels by pressing the wheel's pin and inserting the wheel shaft into the main frame. Align the pin with the hole on the frame (A) until it snaps in. Repeat for the opposite side.

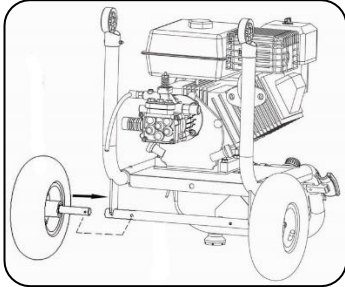

2. Position handle assembly and main frame and connect them with square neck bolt, then fasten with the knob. Repeat this procedure for the opposite side. When storing the machine, you can unscrew the knob and fold down the frame.

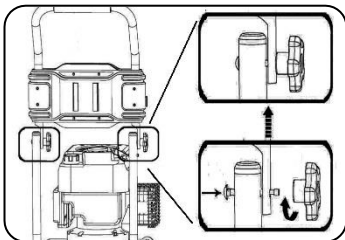

3. Slide the upper gun holster all the way down into the handle assembly.

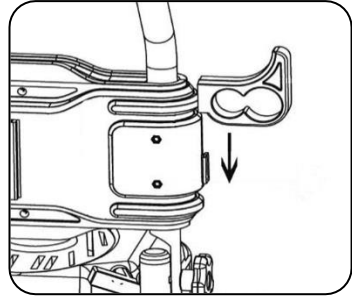

4. Attach the hose hook to the back of handle assembly until it slides into place.

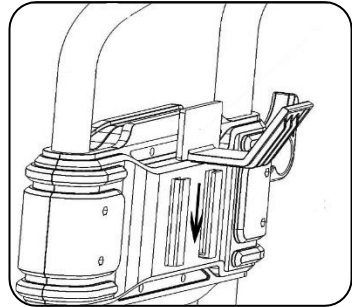

5. Assemble the spray gun with the metal wand. Pull back the rubber piece to expose the threaded fitting. Then, screw the two pieces together and move the rubber piece back.

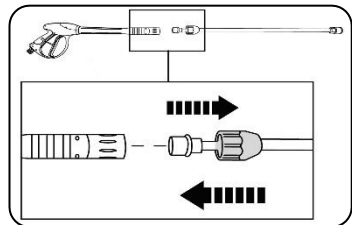

6, PREPARATION

1. OIL LEVEL

⚠ WARNING!

Pressure washer has no oil currently in crankcase! Operating the unit without the correct amount of oil will damage the engine. Always check the oil level before starting the engine, make sure the pressure washer is on a level surface before checking oil level.

Check the oil level:

- 1) Turn the oil gauge dipstick counter clockwise; remove it and clean it with a clean cloth.
- 2) Fully reinsert the oil gauge dipstick and pull it out to check the oil level.
- 3) If the oil level is halfway up the dipstick or below, refill with SAE 10W-30 oil through the dipstick hole until the oil level reaches 3/4 up the dipstick or until it reaches the bottom lip of the dipstick hole as shown in illustration to the right.

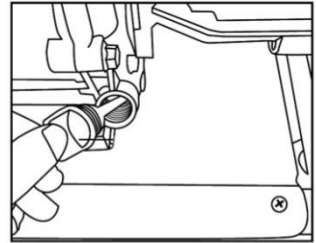

✧ **Always use SAE 10W-30 oil.**

✧ **Oil crankcase capacity: 0.6L**

- 4) Reposition the oil gauge dipstick and tighten it by turning clockwise.



2. FUEL LEVEL

⚠ WARNING!

Make sure there is enough fuel in the fuel tank before operating. This is a 4-cycle engine and does not require a gas/oil mixture. There is a separate reservoir for gas and a separate reservoir for oil.

GPW2600 GAS PRESSURE WASHER

- 1) If it is necessary to add fuel, first make sure the engine is OFF, and then remove the fuel cap by turning it counter clockwise.
- 2) When refueling, make sure the fuel filter is in place and keep in mind all safety precautions.
- 3) Use clean unleaded gasoline with a minimum of 87 octane. DO NOT use old gas. DO NOT mix oil with gasoline.

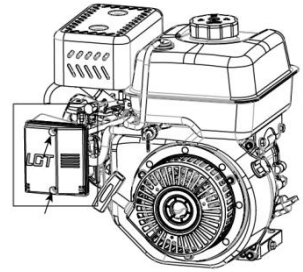

✧ **Fuel tank capacity: 2.7L.**

3. AIR FILTER

WARNING!

The air filter should be checked after prolonged storage, the following steps should be done when checking the air filter. It is recommended to replace the air filter once every spring.

- 1) Screw off the nut on the cover anticlockwise, take down the cover.
- 2) Remove the air filter, wash filter in kerosene, squeeze kerosene out, soak filter in engine oil and squeeze engine oil out.
- 3) Replace filter and replace the air filter cover.

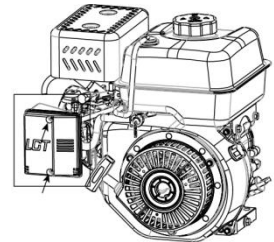

7, OPERATING INSTRUCTION

1. STARTINGPROCEDURE

- Connect garden hose

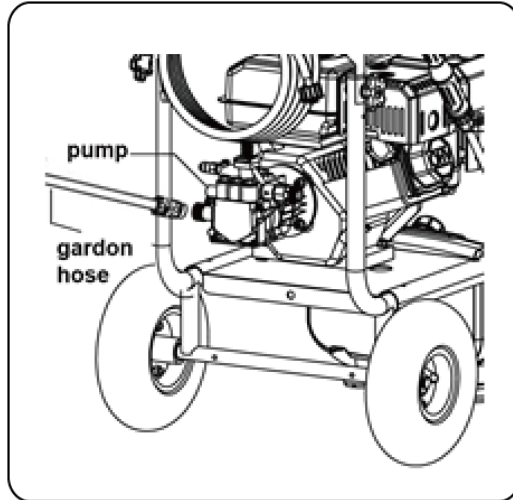

- Connect spray gun and pressure hose

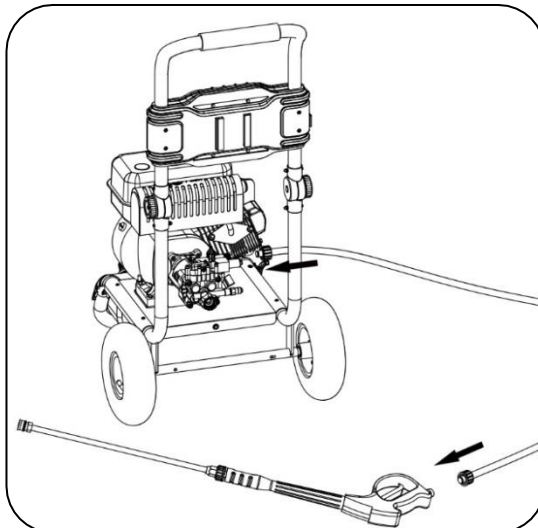

GPW2600 GAS PRESSURE WASHER

➤ Open water source

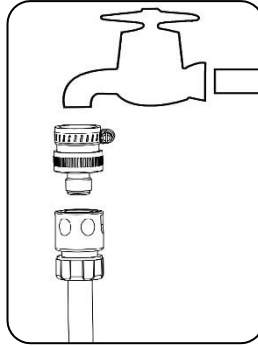

Supply Water

➤ Start engine

 **WARNING!**

Make sure to check the oil level and fuel level to prevent engine damage.

GPW2600 GAS PRESSURE WASHER

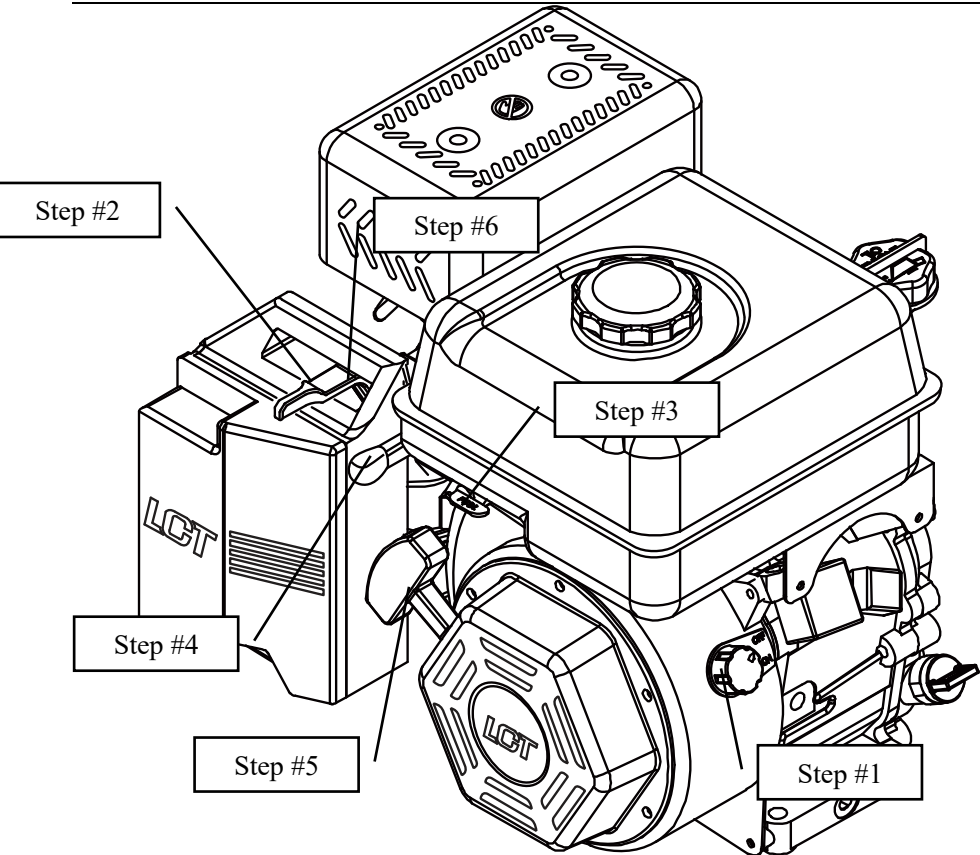

Step #1: Turn the engine switch into “ON” position.

Step #2: Locate choke lever to “CLOSE” position.

Step #3: Turn the fuel valve into “ON” position.

Step #4: Put the throttle lever to the “FAST” position.

Step #5: Locate recoil cord and pull slowly until resistance is felt. At this point, pull rapidly to start engine.

Step #6: After engine starting, locate choke lever to “OPEN” position.

✧ **TIPS:** *If unable to start the engine, please repeat the above operation one or two times.*

GPW2600 GAS PRESSURE WASHER

- ✧ **NOTICE:** When the environment temperature is higher such as summer, or engine is in a hot state, choke valve should be switched to "ON" or intermediate position, then start the engine.

2. INSTRUCTIONS FOR USE

➤ Cleaning operation

Position the tip of the wand 6-8" (15-20 cm) away from the surface to clean at a 45° angle.

➤ Nozzles

This pressure washer comes with 5 different pattern of nozzles.

RED 0°: Thin and powerful stream of water for difficult stains and debris removal.

YELLOW 15°: Thin angled spray for focused cleaning.

GREEN 25°: Medium angled spray for focused cleaning.

WHITE 40°: Large fan pattern for wider cleaning applications.

BLACK detergent: This nozzle must be used in conjunction with a cleaning detergent at low pressure. Only use this nozzle when using a detergent or cleaning solution.

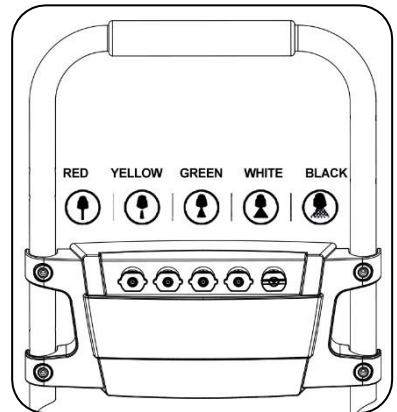
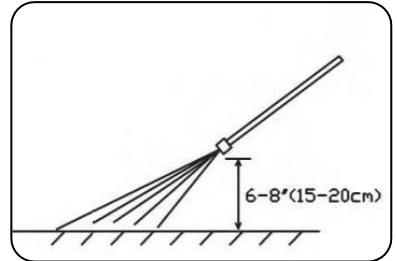

➤ ADJUSTING WATER PRESSURE

GPW2600 GAS PRESSURE WASHER

This engine comes with a throttle lever. The pressure can be adjusted by changing the speed of engine.

Turning the throttle lever to the left can increase the speed to get more pressure.

Turning the throttle lever to the right can decrease the speed to get less pressure.

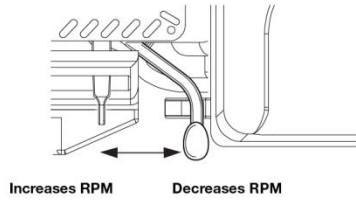

⚠ WARNING!

When moving the engine throttle to the minimum (rightmost), the output power of engine is low. Please don't operate the machine, if not, the machine will be flameout stop due to low engine output power.

➤ **DETERGENT INJECTOR (LOW PRESSURE)**

This pressure equips a detergent bottle. Pure detergent into the bottle, and fit black nozzle on the wand, then squeeze the trigger. The detergent will be mixed with water and sprayed out. It will achieve a better cleaning effect.

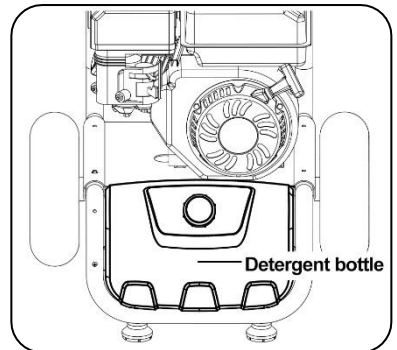

⚠ WARNING!

This pressure washer is intended for use with pressure washer detergents only.

Do not use powdered soaps which will clog the injection system. Follow the detergent manufacturer's directions.

GPW2600 GAS PRESSURE WASHER

WARNING!

Some cleaning jobs can be completed by using only water, but for most, it is advantageous to use a detergent to penetrate and remove the dirt more effectively. When using pressure washer approved detergent, make sure the surface to clean is dry. Wetting the surface first is not recommended; it will dilute the detergent and will reduce the cleaning effectiveness.

Avoid hot surfaces or direct sunlight; this will minimize the chances of the detergent damaging the painted surface.

DO NOT let the detergent dry or it may damage the painted surface.

Allow the detergent to remain on the surface for a short time before rinsing with clean water under high pressure.

➤ **Shut down the pressure washer**

Step #1: Turn the engine switch into “OFF” position to shut down the engine.

Step #2: Turn the fuel valve into “OFF” position to cut off the fuel..

Step #3: Squeeze the trigger of spray gun, release the pressure inside the pump.

Step #4: Cut off the water supply.

Step #5: Squeeze the trigger again to drain the rest water of system.

Step #6: Disconnect the pressure hose and spray gun.

Step #7: Put the gun and hose on the hook.

All done!

GPW2600 GAS PRESSURE WASHER

8, TROUBLESHOOTING

PROBLEM	POSSIBLE CAUSE	SOLUTION	
Engine	Engine doesn't start or is difficult to start	The engine power switch is in OFF (o) position	Ensure the switch is in ON (I) position
		No fuel	Fill the fuel tank with regular gasoline
		Low oil shut down sensor tripped to protect engine (not applicable to 2600 psi pressure washer)	Add oil until it reaches minimum level on dip stick
		Excess water pressure in pump or hose	Release water pressure by squeezing trigger on gun
		Choke lever not in right position	1. When cold starting the engine, set the choke to START or OFF . 2. When warm starting, set the choke to RUN or ON or try the middle position.
		Clogged carburetor	Clean the carburetor. Refer to the instruction manual
		Carbon build-up on spark plug	Clean the spark plug. Refer to the instruction manual
		Incorrect starting method	Use correct starting method. Refer to the instruction manual
	Engine stops after starting	Low oil or no fuel	Check oil and fuel levels
		Choke lever in Start position	Move the choke lever to RUN position immediately after starting the engine
	Engine lacks power	Clogged air filter	Clean or replace the air filter. Refer to the instruction manual
		Clogged carburetor	Clean the carburetor. Refer to the instruction manual
	Engine stops while moving or being tiled	Low oil shut down sensor tripped to protect engine (not applicable to 2600 psi pressure washer)	Do not tilt the machine past 15° when operating. Check oil level and ensure it is above the minimum level on the dip stick
	Carburetor leaks	Carburetor is clogged	Clean the carburetor. Refer to the instruction manual
	Starter rope doesn't recoil	Recoil mechanism is broken	Call customer service toll-free
Engine sounds abnormal or overloaded	RPM too low	Adjust throttle lever to Fast position	
	Clogged nozzle	Clean nozzle with tip cleaner	
	Pressure is too high	Call customer service toll-free	

GPW2600 GAS PRESSURE WASHER

PROBLEM		POSSIBLE CAUSE	SOLUTION
Pump	No pressure, low pressure	Nozzle tip not attached	Attach required nozzle tip
		Water supply faucet closed	Turn on faucet. Ensure there are no kinks or blockage in hose
		Water supply pressure is low	Ensure faucet is fully opened. Check to make sure water supply is a minimum 30 psi, 4 GPM
		Inlet water filter is clogged	Clean the water filter. Refer to the instruction manual
		Air in pump	Squeeze trigger to release the air in pump when the machine is running
		The loaded RPM is not set to FAST	Set RPM (throttle lever) to FAST position
		Clogged check valve	Call customer service toll-free
		Damaged pump	Call customer service toll-free
	Pressure too high	Clogged nozzle	Clean nozzle with tip cleaner
	Water or oil leaks out of pump	Damaged seal ring	Call customer service toll-free
Cold water keeps draining out of thermal relief valve	Defective thermal relief valve	Call customer service toll-free	
Accessories & Connections	No intake of detergent	The detergent siphon tube is not connected	Connect detergent siphon tube properly. Refer to the instruction manual
		Damaged detergent siphon tube	Replace the detergent siphon tube
		Wrong nozzle	Use black nozzle when applying detergent. Refer to the instruction manual
		Detergent adjustment knob set to wrong position	Check adjustment knob. Refer to the instruction manual
		Clogged nozzle	Clean nozzle
		Clogged pump detergent siphon fitting	Detach the detergent siphon tube and clean the fitting with tip cleaner
		Detergent is too thick. Clogged detergent filter	Use only detergent approved for use with pressure washer
		Only applies to GPW2600 2600 psi pressure washer	Clean detergent filter
	The trigger can't be squeezed	Safety lock is not open	Open the safety lock. Refer to the instruction manual
	There is water leakage at joints/connections on gun, hose and/or pump	Damaged seal ring	Change with back-up O-ring or purchase accessory kit
	High pressure hose can't be connected to pump or gun	The O rings are not lubricated	Put lubricating oil or water on the O rings

9, MAINTENANCE

➤ WATER INLET FILTER:

This pressure washer is equipped with a water inlet filter.

This water filter must be kept clean at all times or else it will restrict the water flow to the pressure washer and may damage the pump.

Remove the quick connect coupling from the water inlet, then remove and clean water filter.

DO NOT operate this pressure washer without the water inlet filter in place as deposits could build up internally and affect the functioning of the unit.

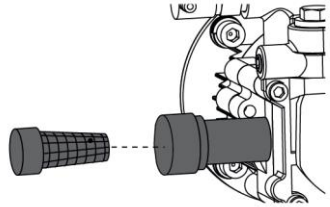

➤ ENGINE MAINTAINENCE:

Engine oil should be replaced after the first 5 hours of operation.

It should be replaced every 100 hours or every year.

To replace engine oil: loosen the oil gauge dipstick. Place an oil pan underneath drain hex screw, remove hex screw and drain oil. Once all the oil has completely drained, retighten the hex screw.

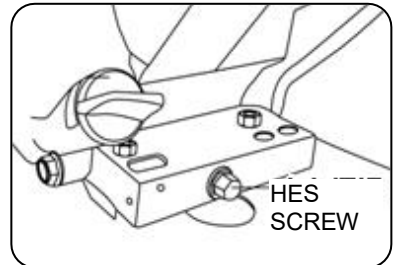

****It is recommended to use SAE10W-30 4-stroke gasoline engine oil.*

****Fill with clean engine oil through the oil gauge dipstick hole to recommended level.*

GPW2600 GAS PRESSURE WASHER

➤ CLEANING CARBURETOR

- 1) Screw down the bolt on the bottom of carburetor with wrench.
- 2) Push the float up four to five times, then clean sediment cup with gas.
- 3) Put the sediment cup back.

*** *Be careful not to miss the O ring.*

➤ INSPECTING SPARK PLUG

The spark plug should be checked every 100 hours of operation or every year.

➤ REPLACING AND CLEANING SPARK PLUG

- 1) Dismantle the spark plug wire by pulling it off the spark plug. Using the supplied spark plug wrench, undo the spark plug by turning counter clockwise.
- 2) Check to see if there is carbon sediment build-up, if so, remove it. If the carbon sediment is excessive, replace the spark plug.
- 3) Measure the electrodes clearance using a feeler gauge. The spark plug electrode clearance should be 0.7-0.8 mm. If the clearance exceeds 0.8 mm, replace the spark plug.
- 4) Reinstall spark plug in the reverse order.

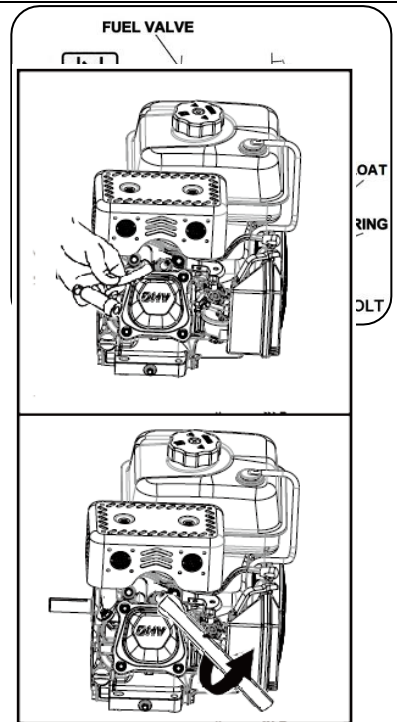

10, STORAGE

➤ FUEL STABILIZER

- 1) Add fuel stabilizer to fuel tank to minimize the formation of fuel gum deposits during storage.
- 2) Run engine at least 5 minutes after adding stabilizer to allow it to enter the fuel system.

NOTE: If a fuel stabilizer is not used, all gasoline must be drained from the tank and carburetor to prevent gum deposits from forming on these parts and causing possible malfunction of the engine.

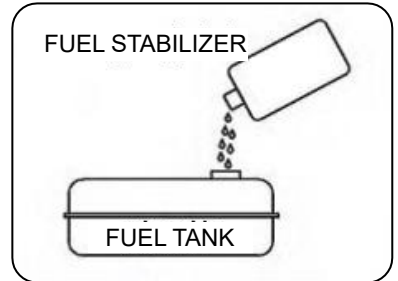

➤ DRAINING FUEL

- 1) Turn fuel valve to the "OFF" position, remove drain hex screw from the carburetor.
- 2) Now turn fuel valve to the "ON" position and drain the fuel from the tank, carburetor and hose.
- 3) Reposition the carburetor drain hex screw once the fuel is completely drained.

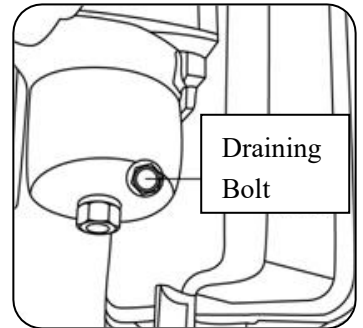

➤ DRAINING OIL

Refer to → PAGE 19 ENGINE MAINTAINENCE.

GPW2600 GAS PRESSURE WASHER

➤ RUST PROTECTION

- 1) Pour approximately one teaspoon of engine oil through the spark plug hole and pull the recoil starter slowly until you feel increased pressure which indicates the piston is on its compression stroke and leave it in this position. This closes both the intake and exhaust valves to prevent the inside of the cylinder from rusting.
- 2) Cover the pressure washer and store it in a clean, well ventilated and dry place. Ensure storage area is at room temperature.
- 3) In addition, in order to prevent external parts rust, please daub anti-rust oil to bolts and nuts of machine at least every one year.

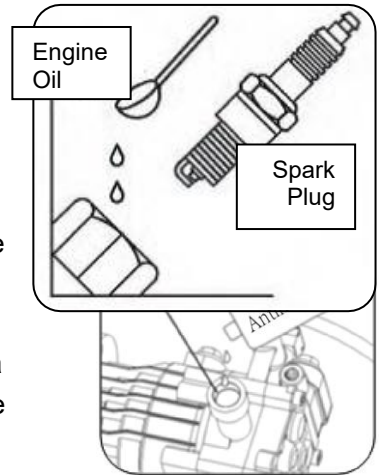

➤ PUMP ANTIFREEZE

If your pressure washer is subjected to freezing temperatures, damage could occur. This type of damage is not covered under warranty. To avoid possible damage, a small amount of antifreeze can be used.

- 1) Place the unit on its side with the water inlet facing upwards, pour 1/4 cup of antifreeze into the water inlet.
- 2) Disconnect spark plug wire, and then pull recoil starter several times to circulate the antifreeze in the pump system. Reconnect spark plug wire.
- 3) It is also important to make sure the wand and all hoses are disconnected and drained of all water or they may burst.

When taking pressure washer out of storage, run water through the system until it runs clear.

GPW2600 GAS PRESSURE WASHER

10. LIMITED WARRANTY

Always keep your receipt as proof of purchase.

We're here to help! If you have any questions or comments, call our Toll-Free 1-888-834-4218. Have your serial number ready. The serial number can be found on the back plate, located on the rear of the unit.

This product has a Parts Replacement, Product Exchange and/or Repair Warranty only.

NO REFUNDS will be provided. Please see stores for Product Exchange details.

One-Year Warranty – Motor

This product is guaranteed to be free from defects in material and workmanship for one year from the date of its original purchase. If such a defect appears during the warranty period, upon presentation of proof of purchase, American Warranty Service (AWS) will repair or replace the product (at its discretion). Shipping charges may apply.

Ninety-(90)-Day Warranty – Accessories

Trigger gun, hose, spray wands and other accessories are guaranteed for 90 days from the date of purchase. You may purchase accessories directly through the place of purchase or by calling our Toll-Free number **1-888-834-4218**.

This warranty does not cover accidental damage, unreasonable use, normal wear and tear, use of improper detergents, freezing, neglecter non-compliance with the operating instructions. The warranty does not cover loss of use or other consequential damages arising from any of the above, nor does it cover repairs made or attempted by unauthorized persons.

The warranty is void if the equipment is used for commercial, rental, or industrial purposes.

If you have further questions, please visit our website (www.green-poweramerica.com, or www.g-pamerica.com) or call Toll-Free number 1-888-834-4218.

GPW2600 GAS PRESSURE WASHER

Distributed By:

Green-Power America, LLC

www.Green-PowerAmerica.com or www.G-PAmerica.com

©All Copy Right are reserved by Green-Power America, LLC